



**Inquire** wearable thin client™  
**User Instructions**

draft

---

# Contents

---

<b>This is the Inroad Inquire</b>	<b>page 3</b>
<b>Inquire Construction</b>	<b>page 5</b>
<b>How to Use the Inroad Inquire</b>	<b>page 12</b>
<b>Setting Up an Inquire Network</b>	<b>page 14</b>
<b>Diagnostic Mode</b>	<b>page 15</b>
<b>Parts and Accessories</b>	<b>page 16</b>
<b>Specifications</b>	<b>page 17</b>

## FCC Notice

---

This equipment has been tested and found to comply with the limits for a Class B digital device, pursuant to Part 15 of the FCC Rules. These limits are designed to provide reasonable protection against harmful interference in a residential installation. This equipment generates, uses, and can radiate radio frequency energy and if not installed and used in accordance with the instruction manual, may cause harmful interference to radio communications. However, there is no guarantee that interference will not occur in a particular installation. If this device does cause harmful interference to radio or television reception, which can be determined by turning the equipment off and on, the user is encouraged to try to correct the interference by one or more of the following measures:

- Reorient or relocate the receiving antenna.
- Increase the separation between the equipment and receiver.
- Connect the equipment into an outlet or circuit different from that to which the receiver is connected.
- Consult the dealer or an experienced radio/TV technician for help.

Caution: Any changes or modifications not expressly approved by the grantee of this device could void the user's authority to operate the equipment.

©August, 1998, Inroad, Inc. All rights reserved. Inroad Inquire and Wearable Thin Client are trademarks of Inroad, Inc. All other product or service names mentioned belong to their respective owners.

Inroad Incorporated  
2025 First Avenue  
Market Place Tower, Suite 1250  
Seattle, WA 98121  
tel: 206.448.7956  
fax: 206.269.4445  
www.inroad.com

draft

## This is the Inroad Inquire

---



The Inroad Inquire wearable computer is a voice-activated, wearable, wireless information access device made up of the following components:

- Wearable client which includes a CPU module and battery pack, wired remote control unit, and headset (headphones, microphone, antenna).
- Server. Since the Inquire client devices use standard network protocols, any Windows NT 4.0 or UNIX computer can be configured to act as a server for one or more clients.
- The software which links the wearable client and the server.

The Inroad Inquire wearable computer is designed for heads-up, hands-free, or hands-minimal operation. The CPU module is worn on a belt or harness with a hardwired connection to the headset and remote control. The operator interfaces with the client by speaking commands into the microphone. Speech recognition software, converts speech into phonyms and transmits the phonyms to a server via radio. The server converts the phonyms into words and phrases according to a predefined application-specific grammar.

The Inroad Inquire's software architecture is based on a client server model in which one or more wearable thin clients are served by and are dependent on a single server. The server hosts the major computing resources, non-volatile storage and all user-configuration information. The server acts as a router between a company's

existing network and a dedicated network of access points that communicate with the thin client. A typical installation is shown below:

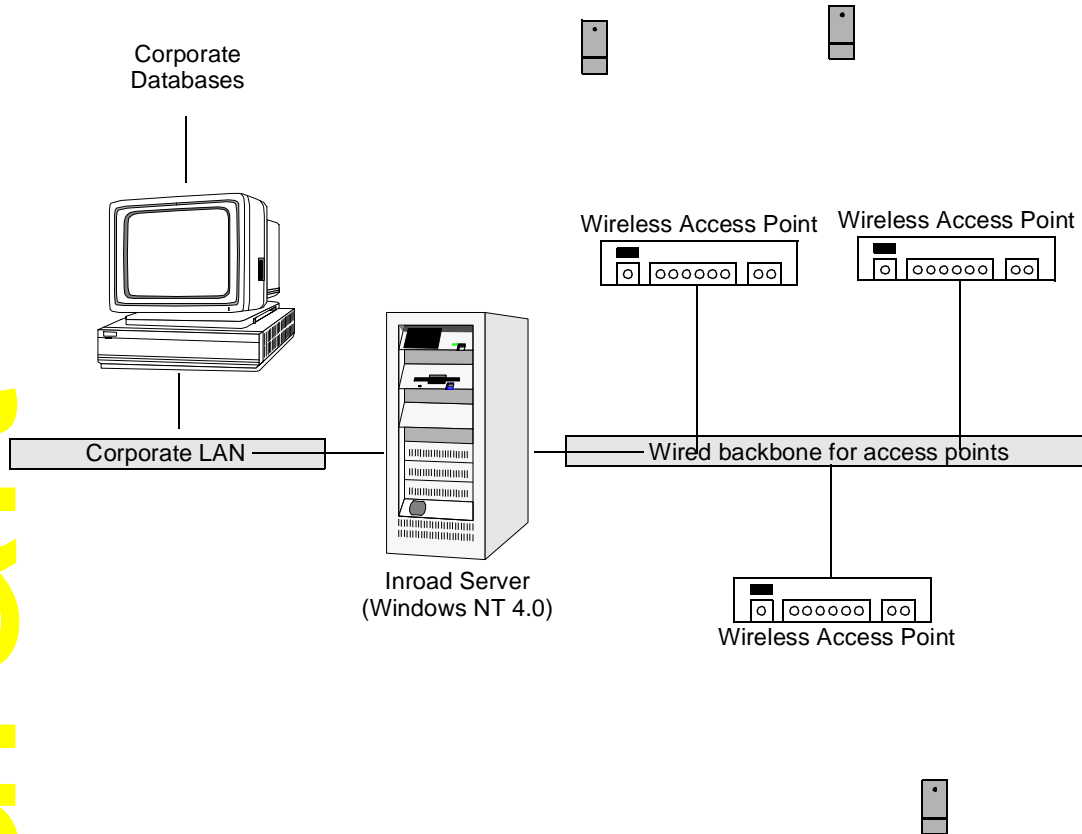

Inroad Inquire client/server configuration

The wearable client and server communicate via an RF link: a 2.4 GHz, frequency hopping wireless local area network (WLAN). The radio module is a standard type III PCMCIA form factor that facilitates upgrades as wireless technology evolves.

The Inquire is powered by a 4-cell, Lithium Ion rechargeable battery pack. Battery packs are removable and rechargeable on a stand-alone battery charger.

draft

# Inquire Construction

## CPU / battery pack



The CPU enclosure is made from die cast magnesium and sealed against environmental contamination to IPX [TBD]. The CPU module has three external connectors to the: remote, I/O, and RF antenna.

The battery pack enclosure is made from injection molded polyester. The battery pack detaches from the CPU for recharging on a stand-alone battery charger.

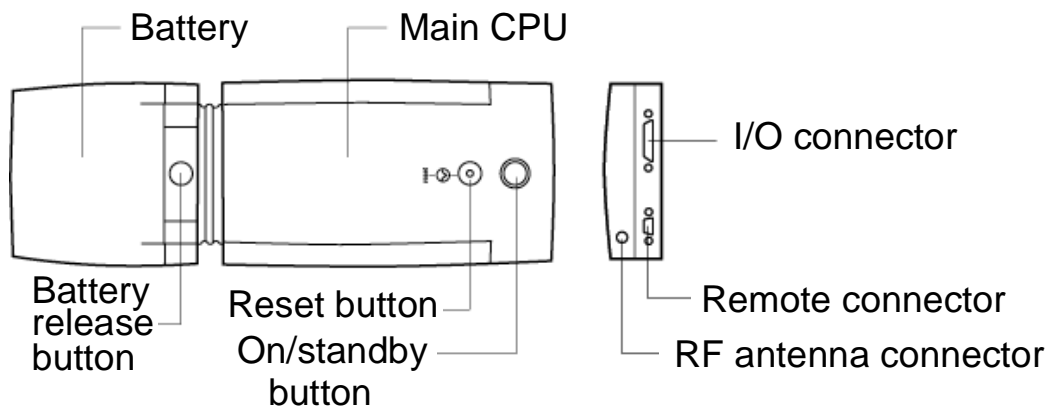

Inquire CPU controls and connectors

draft

An explanation of the CPU's push buttons and connectors is provided in the table below:

---

CPU / Battery Pack push buttons and connectors

---

Power On/ Standby	Toggles between power on and standby mode.
Reset	Pressing the recessed button performs a hard reset on the entire system.
Battery Release	Releases battery pack from module to replace/recharge.
Remote Control Connector	Links the CPU module to the remote control switches and annunciators, and the headset (microphone and earphones)
I/O connector	<p>Allows the Inquire to accept input from a bar code scanner. Two pins provide 5.0 volts and ground. The 5 volt bus is current limited to 300mA through a resettable fuse (the fuse is not operator-replaceable).</p> <p>The Inquire has one general purpose serial interface port. Four signal lines provide either RS-232 or RS-485 communications under software control. Line configurations are:</p> <p>RS-232: The lines are TxD, RxD, RTS, CTS</p> <p>RS-485: The output and input lines are tied together to form a bidirectional differential data bus.</p>

---

### Remote Control

---



---

Inquire remote control unit

The remote control enclosure is made from injection molded polyester. It has two push button controls: push-to-talk and microphone on/off. It has an LCD that displays status icons for power on, reset, radio signal strength, battery charge, and

draft

push-to-talk on. A molded-in pig tail cable connects the remote control to the CPU and headset/antenna.

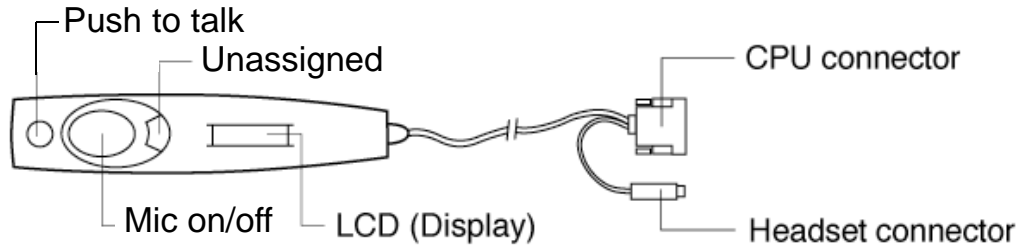

Inquire remote control controls and connectors

An explanation of the icons and the push buttons is provided in the table below.

Inquire Controls and Indicators

Push-to-talk	An optional mode in which the button must be held down while speaking to the device. When talk is enabled, a microphone icon appears on the remote control LCD.
Microphone On/off	Toggles microphone on or off.
CPU connector	Connects the remote control to CPU/battery module
Headset connector	Connects the remote control to the headset



Flashing circle: Unit is beginning to boot.

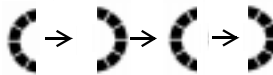

“Flapping ears:” Unit is obtaining boot information from server.



“Pendulum:” Unit is running normally.



LCD icon: ERROR condition. Indicates CPU reset required. (May not have a segmented circle around “v” symbol.)



LCD icon: No radio signal.

draft

---

Inquire Controls and Indicators (Continued)

---



LCD icon: Weak radio signal.



LCD icon: Strong radio signal.



LCD icon: Activated when unit is listening for user speech.



LCD icon: Fully charged battery.



LCD icon: Low battery.



LCD icon: Charge battery immediately (flashing).



CPU rear panel label: Recycle battery.



CPU rear panel label: Recycle battery.



CPU rear panel label: No operator serviceable components.

---

draft

## Headset

---



---

### Headset and antenna

The headset is designed for continuous long-term use in very noisy environments. Headphone output is provided for headphones of  $8\Omega$  minimum. At 8W, up to 250mW power is available to each channel. The noise-canceling microphone eliminates background sounds and transmits voice clarity without variance.

---

### Microphone specifications

Bias power supply	1.2 - 20 volts
Bias series resistance	$3k\Omega$ - $5k\Omega$
Frequency response	35Hz - 6.7Hz $\pm 3$ dB
Noise level (relative to clipping level)	-40dB / $2k\Omega$ load; -55dB / $0\Omega$ load
Microphone sensitivity	-43dB re 1V/Pa / $10k\Omega$ load

## Antenna

---

The antenna is located in the softcase and harness assembly. It attaches to the main CPU through a non-standard, reverse polarity MCX connector.

---

### Antenna specifications

Ideal gain	2.1dBi
Frequency range	2.400 - 2.483GHz
Nominal impedance	$50\Omega$
USWR	<2:1

---

Antenna specifications (Continued)

Pattern	Omnidirectional
Polarization	Vertical

---

**Softcase and harness**

---

During use, the CPU and battery pack are housed in a soft case of padded nylon and worn on a harness of nylon webbing.

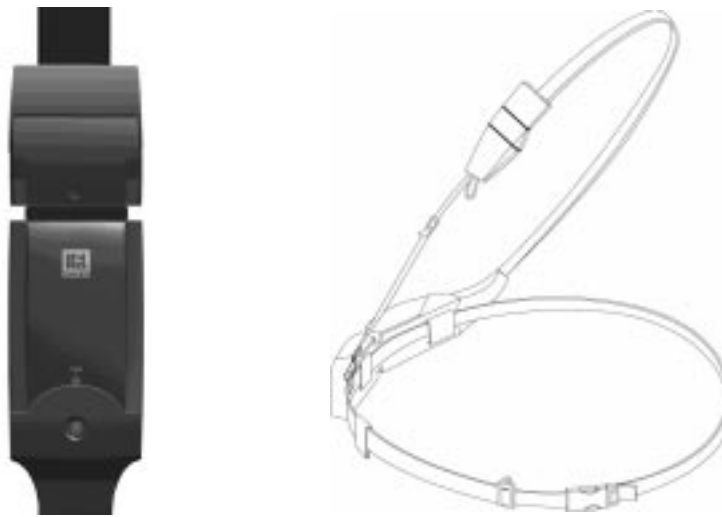

---

Softcase and harness

---

**Power Supply**

---

The Inroad Inquire is powered by a four cell Lithium Ion “smart” battery pack with back-up power provided by a system rechargeable LiON vanadium pentoxide battery.

**Battery Pack**

The battery pack is a “smart battery” with four rechargeable LiON cells and a PCB that controls and monitors battery functions. The level of battery charge is communicated to the wearable client via a one-wire communication line. The battery pack is nominally rated at 14.4 volts, 20 watt-hours.

The LiON battery pack is housed in a battery module which is attached to the CPU module. The battery pack can be removed from the battery module for recharging on the Inroad battery charger.

draft

### **Back-up Battery**

Back-up power, used to maintain SDRAM contents, real time clock, and to operate the power-management processor during battery pack replacement, is provided by a system rechargeable LiON vanadium pentoxide battery.

### **Battery Charger**

Depleted battery packs must be removed from the Inquire for recharging. The battery charger can recharge two battery packs independently. Charge time is approximately four hours.

### **Memory and Memory Options**

---

The system is supplied with a standard 16 Mbytes of SDRAM which resides on a RAM module. Boot code, operating system kernel, and critical software are stored locally in flash ROM. The system has 4 Mbytes of flash ROM, standard. This capacity can be increased by replacing the standard module with a higher capacity module. All upgrades must be factory installed.

draft

# How to Use the Inroad Inquire

---

1. Make sure the battery pack has fully charged batteries.
2. Connect the Inquire Controller to the CPU/Battery Module and to the headset.
3. Press the Power On button. Power on is indicated by a rotating dotted circle on the Controller LCD.

Radio reception strength and battery charge level are indicated by icons on the Controller LCD. For an explanation of remote control icons, see page 7.

## Battery Operation

---

A fully charged Inquire battery pack will power the Inroad Inquire for a minimum of four hours. Depleted batteries are recharged automatically when placed in the Inroad battery charger connected to mains power. Recharging a depleted battery takes approximately four hours.

When placed in the battery charger, battery status is indicated as follows: *[verify]*

- Continuous yellow light means battery is charging.
- Continuous green light means battery is fully charged or that maintenance charging is occurring.
- Continuous red light means battery is faulty and must be removed from use. Recycle according to local regulations.

When the batteries are new, they do not reach a full capacity after the first charge. They must be charged, discharged, and recharged three times in order to reach full capacity.

Battery packs perform best when charged, used, and stored between 15°C to 25°C (59°F to 77°F). High temperatures accelerate the loss of charge and wear out the Battery pack prematurely. Low temperatures reduce battery capacity.

## Store only fully-charged battery packs

Before storing, fully charge all battery packs including new, or previously used batteries. Charge battery packs at least once every 30 days while in storage, and charge again before using the battery in the Inquire. Leaving a battery pack discharged during storage causes permanent damage to the battery which may affect the battery's useful life.

---

**Note.** Charging or storing battery packs in direct sunlight, near a heat source, in cold storage, or other temperature extremes will adversely affect battery performance and useful life.

When a battery pack has reached the end of its useful life, recycle it in accordance with local regulations.

draft

**I/O Options**

---

**Scanner**

N/A

**RS-232/RS-485**

N/A

draft

# Setting Up an Inquire Network

---

## Required Hardware

---

The following hardware is the minimum required to set up an Inroad Inquire wireless network:

Server:	IBM/PC compatible with Windows NT 4.0, minimum 166 MHz
Ethernet cable	2 required
Network hub	10Base-T
Proxim wireless access points	(one or more)
Inroad Inquire	Thin client, remote control unit, battery, headset.

## Required Software

---

The following software is the minimum required:

BOOTP server  
TFTP server  
SpeechNet speech recognition software  
Customer's application software

## Set up the hardware

---

1. Connect the Inroad server to the corporate LAN.
2. Connect the first ethernet cable to the Inroad server and 10Base-T hub.
3. After connecting the server to the corporate LAN, connect the Proxim wireless access point(s) to the LAN as well. (Don't connect the access point to the sever.)
4. Connect server to main power.

## Install Software

---

Following vendors instructions:

1. Install and configure BOOTP server software.  
Optional: The Inquire CPU/Battery Pack may be connected to an RS-232 terminal via Inroad cable PN TBD to monitor BOOTP operation.
2. Install and configure TFTP server software.
3. Install SpeechNet software.
4. Install customer application software.

draft

# Diagnostic Mode

---

To enter diagnostic mode:

1. Connect the Inquire CPU/Battery Pack to a terminal via Inroad cable PN TBD.
2. Simultaneously press the power and reset push-buttons. Release reset while continuing to hold down the power button until the unit boots.

The following menu appears on the terminal screen:

```
Selection Description
-----
1 LCD Test
2 Button Test
3 Radio Test
4 CODEC Test
5 Keyboard Test
6 Configure Device
7 Start Power-age
8 Quit

Enter a selection number menu->
```

3. To test an Inquire function, enter a selection number 1 through 5. To perform power-age, enter selection number 7. Enter selection number 6 to configure the Inquire. The configuration menu appears:

```
===== Starting Config Menu =====
Selection Description
-----
1 Set IP Address
2 Set Subnet Mask
3 Set Config FileName
4 Set Host IP Address
5 Set Radio Domain
6 Set Radio Security ID
7 Print Config
8 Go back to previous menu

Enter a selection number menu->
```

4. Configure the Inquire as desired. To exit the configuration menu, enter selection number 8.
5. To exit diagnostic mode, enter selection number 8.

draft

## Parts and Accessories

---

To order parts and accessories:

- In North America call 1-800-TBD.
- In other countries, contact your local Inroad distributor.

Or, to order parts and accessories, or for technical support, visit the Inroad website at [www.inroad.com](http://www.inroad.com).

---

CPU/Battery Pack Module	PN TBD
Controller	PN TBD
Headset	PN TBD
Antenna	PN TBD
Battery Charger	PN TBD
Battery Pack	PN TBD
Quick Reference Card	PN TBD
User Instructions	PN TBD

---

draft

# Specifications

---

## Physical Characteristics

---

<b>Weight</b>	1.4 pounds (635 grams)
<b>Size</b>	3"W x 9.1"L x 1.51"D (7.6 x 22.86 x 3.81cm)
<b>Processor</b>	High speed DEC StrongARM RISC SA110
<b>Memory</b>	16Mb SDRAM (optional 32 or 48Mb), 4Mb flash ROM (optional 8Mb)
<b>I/O connections</b>	Bar code scanner/keyboard, RS-232/RS-422/RS-485 serial interface
<b>Batteries</b>	Rechargeable lithium ion, 4-cell "smart" battery pack, 12 volts, 20 watt-hour capacity, plus rechargeable internal backup battery.
<b>Battery Life</b>	4 hours minimum
<b>Charge Time</b>	Approximately 2 hours

## Wireless Communications

---

<b>RF Interface</b>	Type III PCMCIA (1) Proxim RangeLAN II. (Other 2.4GHz radios upon request.)
<b>Antenna</b>	External dipole 3" (7.5cm) whip.
<b>Frequency</b>	2.4 – 2.5GHz (North America only)
<b>Data Rate</b>	1.6 Mbps – 800 Kbps
<b>Headset</b>	VXI "Parrot" headset with single covered earphone and flexible microphone. Attachment point for RF antenna included.
<b>Voice Interface</b>	16-bin linear stereo CODEC, one input channel (microphone), two output channels sampled at 16kHz
<b>Microphone</b>	Gentex 3063, Bias power supply: 1.2 – 20V. Bias series resistance: 3k $\Omega$ - 5k $\Omega$ . Frequency response: 35Hz - 6.7Hz $\pm$ 3dB. Noise level: -40dB/2k $\Omega$ load; -55dB/0 $\Omega$ load. Sensitivity: -43dB re 1V/Pa /10k $\Omega$ load.

**Software**

---

- Inroad Inquire** Speech Systems Inc. SpeechNet Speech Recognition/TTS Client
- Sever Software**
- Speech Systems Inc. SpeechNet Speech Recognition/TTS Server
  - Windows NT 4.0 Server (requires installation of DHCP/Bootp service.)
  - TFTP Server

**Environment**

---

- Operating Temperature** -4° to 122° F/-20° to 50°C
- Storage Temperature** -40° to 140° F/-40° to 60°C
- Humidity** MIL-STD-810E, Method 507.3. (5% to 95% noncondensing)
- Sealing** Splash/Spray: MIL-STD-810E, 506.3, Procedure II-drip  
Sand/Dust: MIL-STD-810E, 510.3, Procedure I and II
- Drop** MIL-STD- 810E, Method 516.4. 6 feet/1.5 meter to concrete (at 25°C)
- Vibration** MIL-STD-810E, Method 514.4, Category 10
- Altitude** MIL-STD-810E, Method 500.3, Procedure II
- Compliance** Meets FCC part 15 (North America), ETSI 300.328 (Europe), RCD STD-33 (Japan)

---

Specifications subject to change without notice.